

PlaneSkate™

The Original Aircraft Flat Tire Dolly

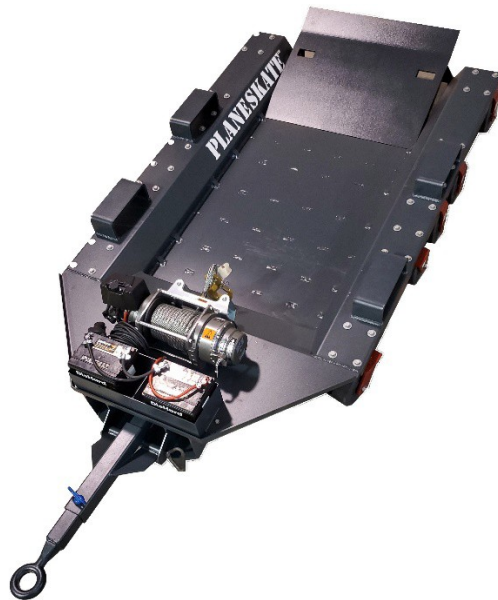

100K

Instruction and Maintenance Manual

West Metro Aviation, LLC.
1313 County Road 134
Buffalo, MN 55362

Phone 763-682-1516 (office) 612-812-3873 (cell)

Safety

The purpose of this safety section of this manual is to inform operators and maintenance personnel of the precautions to be taken while operating or servicing the machine. The following are just a few basic guidelines to follow up, but as with any type of machinery good judgment and a safe attitude should be applied at all times.

1. Always wear safety clothing, including eye protection and protective footwear, while operating or servicing the machine.
2. Keep all body parts and foreign objects away from the ramp, wheels and the winch while operating or servicing the machine. Be aware there are several pinch points located on the machine. 
3. To reduce the risk of injury to operator or bystanders and damage to aircraft, always inspect cable, hook and clip, and tow strap for any signs of wear or damage prior to use.
4. The machine should be operated and maintained by properly trained, authorized personnel.
5. Replacement parts should have the same specification and operation as the original parts on the machine.
6. All guards and covers must be in place before returning machine to service.
7. DO NOT – tow the aircraft on the PlaneSkate™ faster than 5mph/8kph.
8. DO NOT – make sharp turns when towing the aircraft on the PlaneSkate™.
9. DO NOT – tow the aircraft on the PlaneSkate™ over grass or soft surfaces.
10. DO NOT – tow the aircraft on the PlaneSkate™ over concrete hanger floor lips or bumps greater than 1 inch.
11. DO NOT – tow the aircraft on the PlaneSkate™ over large cracks or failed pavement.

**MAXIMUM AIRCRAFT WEIGHT: 100,000 lbs. / 45,359 kg.
THE PLANESKATE™ MAXIMUM CAPACITY: 40,000 lbs. / 18,143 kg.**

NOTE: These safety rules are for your benefit to help prevent injury to yourself and/or your coworkers. Review all set up and operating procedures, whether covered or not, in this manual to help ensure safe operation of the machine.

INSTRUCTIONS FOR LOADING THE 100K PLANESKATE™

MAIN GEAR DISABLED

To reduce the possibility of twisting the airframe as it is being loaded, two people are required to load the disabled aircraft onto the 100K PlaneSkate™. One person to operate the 100K PlaneSkate™ and another to operate a tug. Coordination between the tug operator and the PlaneSkate™ operator is necessary for even loading.

1. Roll the ramp of the PlaneSkate™ up to the front of the flat tire. Chock the front wheels of the PlaneSkate™.
2. Wrap the axle strap around the gear leg. Be cautious not to damage hardware mounted to the strut assembly.
3. Attach the winch cable hook to the axle strap.
4. Operate the winch carefully to tighten the winch cable.
5. Prior to winching the aircraft onto the PlaneSkate™ clear personnel at least 10ft/3m. away from the winch cable.
6. Retract PlaneSkate™ tow bar extension into the stowed position and secure with tow bar extension pin and clip.
7. Coordinate towing the aircraft forward with a tug attached to the nose gear while a separate operator is using the winch to keep the winch cable tight and to keep the PlaneSkate™ aligned with gear.
8. Stop winching when the position of the gear is approximately centered (front-to-rear) on the PlaneSkate™ tray.
9. To keep the gear positioned on the PlaneSkate™ during towing, wood blocks or chocks may be required between the tire and the front of the tray and possibly on the sides of the tire.
10. Using extra ratchet straps secure the strut to the PlaneSkate™.
11. Prior to towing aircraft, raise the ramp into the suspended position using the ramp uplock tabs.



INSTRUCTIONS FOR LOADING THE 100K PLANESKATE™

NOSE GEAR DISABLED

When using the PlaneSkate™ to recover aircraft with the nose gear disabled, you will be able to use the PlaneSkate™ as the wheel and the tow bar. Be sure to have the tow bar in the extended position with the pin and clip secure.

1. Roll the ramp of the PlaneSkate™ up to the front of the flat tire. Chock the front wheels of the PlaneSkate™.
2. Wrap the axle strap around the gear leg. Be cautious not to damage hardware mounted to the strut assembly.
3. Attach the winch cable hook to the axle strap.
4. Operate the winch carefully to tighten the winch cable.
5. Prior to winching the aircraft onto the PlaneSkate™ clear personnel at least 10ft/3m. away from the winch cable.
6. Stop winching when the position of the gear is approximately centered (front-to-rear) on the PlaneSkate™ tray.
7. To keep the gear positioned on the PlaneSkate™ during towing, wood blocks or chocks may be required between the tire and the front of the tray and possibly on the sides of the tire.
8. Using extra ratchet straps secure the strut to the PlaneSkate™.
9. Prior to towing aircraft, raise the ramp into the suspended position using the ramp uplock tabs.

Caution: This is the only way to safely load an aircraft weighing up to 100,000 lbs. GW onto the PlaneSkate™.

The final position of the distressed gear on the PlaneSkate™ is when it is positioned (front to back) between the second and third caster. To accomplish this, blocks of wood or chocks between the tire and front end of the PlaneSkate™ tray may be required.

TOWING WITH THE 100K PLANESKATE™

Towing must always be done from the nose of the aircraft. Under no circumstance should you try to move the aircraft by pulling or pushing on the PlaneSkate™ while it is attached to the main landing gear!

1. Always start out towing the aircraft with great caution and slowly increase your speed up to 5mph/8kph. Never exceed this limit.
2. While towing, do not make sharp turns. As you make a gentle turn, make certain the aircraft is fully secured to the PlaneSkate™ and that it is following the intended path.
3. While recovering the aircraft, do not tow over grass or soft surfaces.
4. Plan and decide the best path to take. You cannot tow the aircraft over large cracks or failed pavement.
5. Be aware that you cannot go over concrete hanger floor lips or bumps greater than 1 inch.

REMOVING THE AIRCRAFT FROM THE 100K PLANESKATE™

The preferred method of removing the aircraft from the PlaneSkate™ is to jack the aircraft wing to clear the PlaneSkate™ and pull the PlaneSkate™ out.

An alternate method is to chock the wheels on the aircraft and attach the tug to the tow bar of the PlaneSkate™ to pull the PlaneSkate™ away from the aircraft.

OR

You can chock the wheels on the PlaneSkate™ then using the tug, push the aircraft off the PlaneSkate™.

If you have questions, concerns, or comments about the use of the PlaneSkate™.

Contact: [West Metro Aviation](#) in Buffalo, Minnesota.

Email: info@westmetroaviation.com

Phone: 763-682-1516

—

Battery Health & Safety



Battery Acid

Battery acid can cause burns. Suitable hand, eye and face protection and protective clothing must be worn.



First Aid

For advice, contact the Poison Control Center (U.S. 1-800-222-1222) or a doctor immediately. If in eyes, hold eyelids apart and flush the eye continuously with running water.

Continue flushing until advised to stop by Poison Control Center or doctor, or at least 15 minutes. If skin or hair contact occurs, remove contaminated clothing and flush skin or hair with running water.



Acid Spill Response

Dam and neutralize spills with soda ash or other suitable alkali. Dispose of residue as chemical waste or as per local requirements.



If Electrolyte is Swallowed

Do NOT induce vomiting – give a glass of water. Seek immediate medical assistance.



Exploding Battery

Batteries generate explosive gases during vehicle operation and when charged separately. Flames, sparks, burning cigarettes or other ignition sources must be kept away at all times. Exercise caution when working with metallic tools or conductors to prevent short circuits and sparks.



Always Wear Eye Protection When Working Near Batteries

When charging batteries, work in a well-ventilated area - never in a closed room. Always turn battery charger off before disconnecting a battery.

Battery Charging



Safety First

Before attempting to charge a battery with an external battery charger, it is important to be aware of the safety precautions when charging batteries and follow the instructions outlined by the charger manufacturer.

1. Turn the charger off before attaching, rocking, or removing the terminal clamps.
2. Keep open flames and sparks away from the battery.
3. Keep vent caps in place.
4. Charge in well ventilated area.
5. Follow the battery charger manufacturer's instructions to avoid overheating.

Dangerous explosive gases are generated during the charging process that can be ignited by a variety of sources including, sparks, naked flames, and static electricity. It is highly recommended to wear PPE (Personal Protection Equipment) including safety glasses, chemical resistant gloves, and overalls.

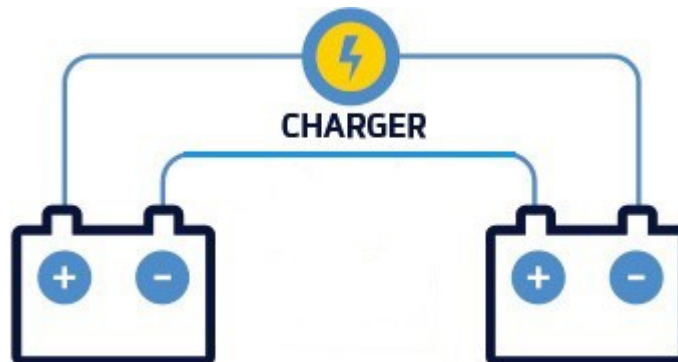

- When connecting 12-volt batteries in series, you are increasing the voltage of the battery bank while maintaining the current. E.g., 3 x 12-volt 60Ah batteries when series connected will create a 36-volt 60Ah bank.
- **When charging batteries in series, you must have the correct voltage charger for the number of batteries in the bank. E.g., If you have 2 x 12-volt batteries in series, you must use a 24-volt charger.**

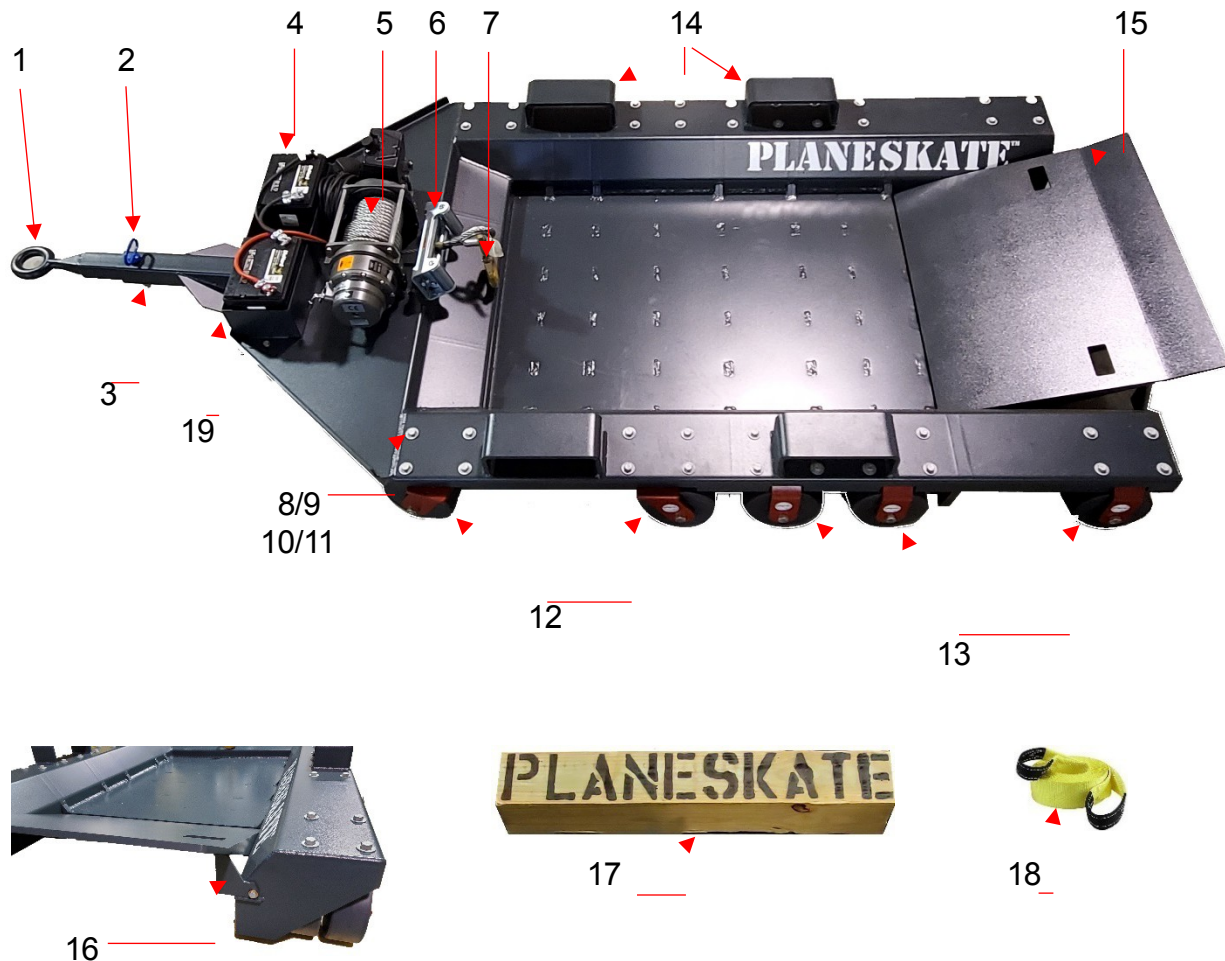

1. Tow Bar/Tongue
2. Tow Bar Extension Pin
3. Tow Bar Extension Pin Hitch Pin Clip
4. (2) 12-volt Batteries In Series
5. Warn Winch Series 18-A-2D w/8" Drum
6. Warn Fairlead (Cable Guide)
7. Hook w/Clip
8. Bolts 1/2"-13x1-1/2"
9. Flat Washers 1/2"
10. Lock Washers 1/2"
11. Nuts 1/2"-13
12. (4) Swivel Casters S-EHD2-83NYB
13. (6) Rigid Casters R-EHD2-83NYB
14. (4) Forklift Pockets
15. Ramp
16. (2) Ramp Uplock tabs
17. (3) 6 x 6 Wheel Chock
18. Axle Strap
19. Tow Bar attach pin and pin clip

Maintenance and Inspection



- Batteries require monthly service to maintain full charge. Depending on use, batteries may require more frequent charging.

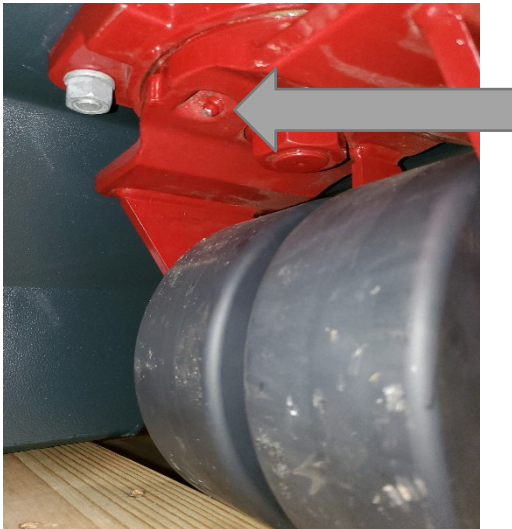

- The swivel wheels have a grease zerk. They require regular monthly service depending on use.



- Winch cable should be inspected after every use to ensure no damage had occurred during the previous use.



- Axle strap should be replaced if there are any cuts, abrasions, or fraying of any kind.